

SUBJECT- ENGLISH

- 1. Read the newspaper daily and write two difficult words daily along with their meaning on ruled sheets. (Minimum 70 words)**
- 2. Read the NOVEL: GREAT EXPECTATIONS BY CHARLES DICKENS and do as directed on A4 size sheets:**
 - a. Character sketch of any two characters.**
 - b. Write 30 difficult words with their synonyms.**
 - c. Write a book review.**
 - d. Make a book cover for the novel.**
- 3. Write any fifteen idioms on an A4 size sheet and make sentences using them.**
- 4. Make a beautiful bookmark for your Golden Leaves. Decorate it and write a quote on it that inspires you.**
- 5. You recently visited Andaman and Nicobar Islands in your holidays. Write a diary entry about all the places you visited during your trip in 200 words. Paste pictures along with it on an A3 size sheet to make it more attractive.**

विषय हिंदी

(1) अंडमान और निकोबार पर एक परियोजना कार्य तैयार करें, जिसका विषय है अंडमान, निकोबार का

जल वायु, तापमान विकास प्रत्येक विषय पर दो पेज तैयार करें।

(2) 10 सुलेख लिखें सुलेख में अनुच्छेद शामिल करें लेखनी स्पष्ट एवं सुंदर हो।

(3) 15 मुहावरे चित्र सहित तैयार करें।

(4) कक्षा में करवाए गए कार्यों को याद करें तथा पूरा करें।

(5) प्रतिदिन समाचार पत्र पढ़ें तथा 10 कठिन शब्द लिखें।

(6) ਸੈਂਜੀਨ ਕੇਲਿਏ ਦੋ article (ਵਿਥਯ) ਤੈਯਾਰ ਕਰੇ।

SUBJECT-PUNJABI

↪ ਅੰਡੇਮਾਨ ਨਿਕੋਬਾਰ ਦੇ ਸੱਭਿਆਚਾਰ ਉੱਪਰ ਇੱਕ Scrap book ਬਣਾਉ।

↪ ਸਾਡੇ ਤਿਉਹਾਰ ਤੇ ਇੱਕ ਮਾਡਲ ਬਣਾਉ।

↪ ਜਮਾਤ ਵਿੱਚ ਕੀਤੇ ਕੰਮ ਦੀ ਦੁਹਰਾਈ ਕਰੋ।

↪ ਮਾਤਾ ਪਿਤਾ ਦਾ ਸਤਿਕਾਰ ਕਿੰਨਾ ਜ਼ਰੂਰੀ ਵਿਸ਼ੇ ਤੇ ਕਵਿਤਾ ਜਾਂ ਪੈਰਾ ਲਿਖੋ।(A4 size sheet)

SUBJECT- MATHEMATICS

GENERAL INSTRUCTIONS:-

1. Project Work to be done in A4 size coloured 1 side Ruled sheets .
2. Assignment to be done neatly on A4size Ruled sheets .Do write the questions also .
3. Both tasks to be clubbed & submit in same file or folder.

Task 1 :

Project Work

Task 2 :

Assignment

PROJECT WORK:-

- Collect the data for temperature for any 1 week of Andaman and Nicobar islands in both Fahrenheit and celsius.
- Represent this data on two different bar graphs showing temperature of 7 days of week in Fahrenheit and celsius both.
- Write the conversion formula from Fahrenheit to celsius and show it with the help of one example.

WORKSHEET 1

CHAPTER 1

Q- 1 Write the additive inverse of the following :-

i) $-6/-5$

ii) $2/-7$

iii) $-5/11$

Q-2 Find the multiplicative inverse of the following:

i) -17 ii) -12/17 iii) 15/16

Q-3 Give one example showing associative property of rational numbers.

Q-4 Write three rational numbers greater than -3.

5. Calculate:-

$$(a) \frac{-4}{5} \times \frac{3}{7} + \frac{4}{5} \times \frac{3}{7} \qquad (b) \frac{1}{2} \times \frac{5}{6} + \frac{1}{3} \times \frac{1}{4}$$

Q-6 _____ is the multiplicative inverse of 5/2.

Q-7 By what number should we multiply -8/13 to get the product 32?

Q-8 Show that:-

$$\left(\frac{-8}{9} \times \frac{1}{-5} \right) + \left(\frac{-8}{9} \times \frac{-7}{11} \right) = \frac{-8}{9} \times \left(\frac{1}{-5} + \frac{-7}{11} \right)$$

Q-9. If $x = 1/7$, $y = 2/3$ and $z = -1/3$. Verify that

$$x(y+z) = (xy) + (xz)$$

Q-10 If the cost of 9/2 litres of milk is ₹ 357/4, find the cost of 1 litre of milk.

WORKSHEET 2

CHAPTER 2

Q-1 Solve:- $3(2x - 3) = 4(2x + 4)$

Q-2 Find the value of x:-

$$4x+5=7-8x$$

Q-3 Solve and verify your answer:-

$$11 - 5x + 3x + 4x = 18$$

Q4 Solve:- $(2x-2)+(3x-3)+(9x-9) = 1$

Q-5 Solve for x :- $5x+21 = 2 \times (x+21)$

Q-6 Find the value of x:-

$$3x/2 - 2x/3 = 8$$

Q-7 Find the value of a, if

$$(a+3)(a-3)-a(a+5) = 6$$

Q-8 If 7 is added to 7 times a number, the result is 28. What is the number?

Q-9 A triangle having a perimeter 56 and its side are $2x$, $2x+3$ and $2x+ 5$. Find the respective lengths of the sides of the triangle.

Q-10 In a class of 96 students, the number of girls are three-fifths of the number of boys. Find the number of boys and girls in the class.

WORKSHEET 3

CHAPTER 3

Q-1 A quadrilateral has three acute angles, each measure 80° . What is the measure of the fourth angle?

Q-2 In a quadrilateral ABCD, $\angle D$ is equal to 150° and $\angle A = \angle B = \angle C$. Find $\angle A$, $\angle B$ and $\angle C$.

Q-3 Name two quadrilaterals in which diagonals bisect each other.

Q-4 Name two quadrilaterals in which diagonals are equal to each other.

Q-5 Name two quadrilaterals in which diagonals are perpendicular to each other.

Q-6 The opposite angles of a parallelogram are $(3x + 5)^\circ$ and $(61 - x)^\circ$. Find the measure of four angles.

Q-7 Find the value of x,y,z.

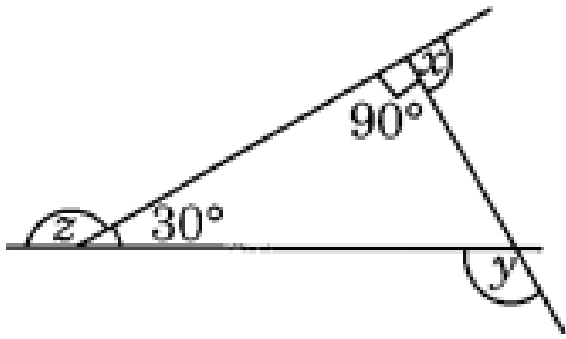

Q-8 Find the unknown values of x, y, z .

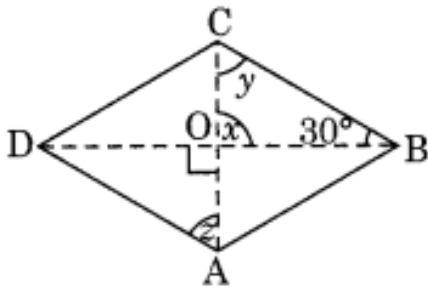

Q-9 Find the value of x, y if ABCD is a parallelogram.

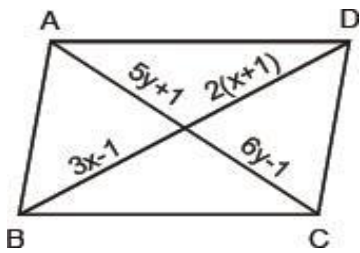

Q-10 Find the value of x and y if PQRS is a parallelogram.

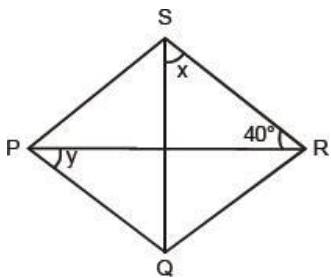

SUBJECT-SCIENCE

1. Complete the science activity file. The PDF for the same will be sent in the class group later.

2. Prepare a 3-D working model highlighting the major reasons for the temperature variations (emphasizing global warming) and altered climate in the Andaman and Nicobar islands and their harmful effects. Use A-4 size sheets to explain your project.

3. Attempt the following two worksheets of ch-1 and ch-2 on separate A-4 size ruled sheets.

WORKSHEET-1

CH-1

Q1. Fill in the blanks:

- 1. crop is harvested in october.**
- 2. The kind of crop grown only for sale profit is**
- 3. is used to till the soil in agriculture.**
- 4. In type of irrigation, water is sprayed on the plants using rotating sprinkler.**
- 5. Threshing can be done using the machine.....**
- 6. Large grasses cultivated for their nutritious seeds are called.....**
- 7. Preparation of soil involves and it.**
- 8. The agricultural implement used to sow seeds is called**
- 9. Allowing a field to remain free of crops for one or more seasons is called field.....
it
allows the field to regain.....**
- 10. Bacteria fixed nitrogen in root nodules of leguminous plants.**
- 11. The practice of growing fruit, vegetables, flowers and ornamental plant is called**
- 12. Removing the chaff from the grain is called.....**
- 13. The method of irrigation in which emitters let out a trickle of water near the roots is called.....**
- 14. Two plantation crops are..... and.....**
- 15. Farmer's friend.....**

16. The production of useful products by growing on a large-scale of plants and rearing animals

is called_____.

17. Growing a particular kind of plant in a particular season and place is called_____.

18. Wheat, barley, rice, maize and oats are examples of_____.

19. The crops that are grown in the monsoon season are called_____ crops.

20. _____ is rich in organic substances.

WORKSHEET-2

CH-2

Q1. Write 10 lines on the usefulness of microorganisms in our lives.

Q2. Write a short paragraph on the harmful effects caused by microorganisms.

Q3. Is it safe to eat infected bread? Why?

Q4. What are the major groups of microorganisms? (Describe in detail their specific features)

Q5. Classify the following into friendly and harmful microorganisms:

1. Yeast

2. malarial parasite

3. Lactobacillus

4. bread mould

5. Rhizobium

6. Bacillus anthracis

Q6. Visit a doctor. Find out why antibiotics should not be overused. Prepare a short report.

SUBJECT: SOCIAL SCIENCE

1. Integrated Project : Pairing of Delhi with Andaman & Nicobar Island and

Lakshadweep Island.

a) Write about people, language and festival celebrated in Delhi along with Andaman & Nicobar Island and Lakshadweep Island and write few lines on these States with map and pictures.

b) Write about famous 5 Tourist places of each with pictures.

2. Make a poster on A4 size with slogan on “Conservation of Flora & Fauna of India”.

3. Design a preamble for your school abiding to all rights and duties of all the students in school. You can also take help from preamble of constitution of India.

4. Collect information on “Lok Sabha Election 2024 in DELHI” from the newspapers and make a beautiful collage on full chart paper with all details and proper headings.

Note : Prepare any one project from the following Topics. Use a project file for this and also Paste relevant pictures.

5. Make a project on the topic “Tribals, Dikus and the vision of a Golden age” using the following guide points:-

(a) Tribal occupation (b) Tribal life under British Rule.

(c) Tribal Revolts (d) Role of Birsa Munda

6. Study the “Revolt of 1857” and make a project. Focus should be laid upon the following;

(a) Causes of revolt (b) Outbreak of the revolt

(c) Why the revolt failed? (d) Result of the revolt

7. Refer to the internet and your text book of history and study the topic ‘Marginalized groups and social injustice’. Make a project using the following points:

(a) Forms of social inequality -Caste System, Untouchability, Adivasis etc.

(b) How social status affects Economics status?

(c) Social justice and the Indian constitution

(d) Laws to help the marginalized

SUBJECT-GK

Read newspaper daily and write the four current affairs in a note book.

SUBJECT-DIVINITY

Make an activity on four Sahibzadas of Sri Guru Gobind Singh ji. Past photos and write ten lines about each of them.

SUBJECT-ART

1. Poster on

(a) SAVE GIRL CHILD

(b) GREEN DELHI CLEAN DELHI

2. Project-

(a) Desk organizer and decorate it with shells (ROLL NO 1 TO 25)

(b) Wind chime with shells (ROLL NO 26 TO 47)

COMPUTER

On A3 Size Sheet Write all the Domains of Artificial Intelligence and make a ppt on it

On A3 Size Sheet Write Some Programming Languages and its purpose and applications and also make the ppt on it

Assignment

I Write the Python programs to do declare two integer variables A and B then do the following.

- 1. Initialize both the variables with same value and check if they are equal then display TWINS**

2. Initialize two variables with different value and check if they are not equal then display DIFFERENT
3. Initialize two variable and one value is greater than other, then display GREAT otherwise display GREAT ANYWAY

II Write the output of the following expressions:

1. Str="INFORMATION TECHNOLOGY"

(a) print(str)

(b) print(str[0])

(c) print(str[1:7])

(d) print(str[0:6])

(e) print(str[4:9])

(f) print(str[-1])

(g) print(str[-7])

2. age=18

print(age)

3. (7==8)and (8!=7)

4. (6==7) and (not(9!=8))

5. (7-15)*2

6. (12-8)*12/4

7. 150/(5%2)

8. "BYE" *4

9. X="HAPPY

Y="HOLIDAYS"

print(X+Y)

10. num=1

while num<15:

print(num)

num=num+1

print("Good")